

Control / Regulation

The **energy consumption of a screw spindle pump** is primarily influenced by the efficiency of the pump, the efficiency of the motor and the sizing of the pump with respect to the working point of the system.

Within the scope of our **seminars** we offer our support for:

- pump selections
- supply you with detailed information on the use of variable frequency drives
- show potential energy savings through pump controls
- support you locally in retrofitting existing applications and systems

For detailed information please do not hesitate to contact us.

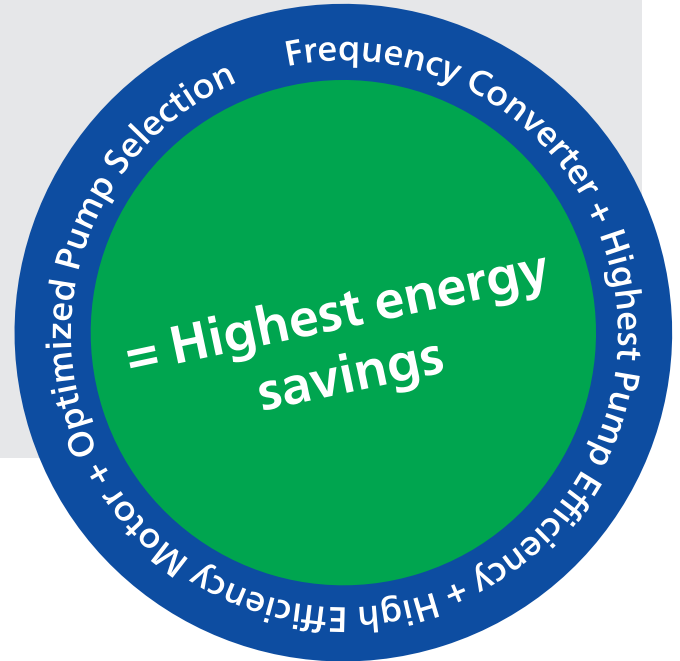

Regulation

Regulation is an operation with which a physical value such as pressure is continuously sensed and compared with a set value. In the event of deviation the regulation device (here a PI controller) provides for the desired adaptation.

With regulation a check is made whether a desired state is achieved or not. This allows for a process to reach a predetermined operating pressure while adjusting the flow of the pump to the required flow of the consumer.

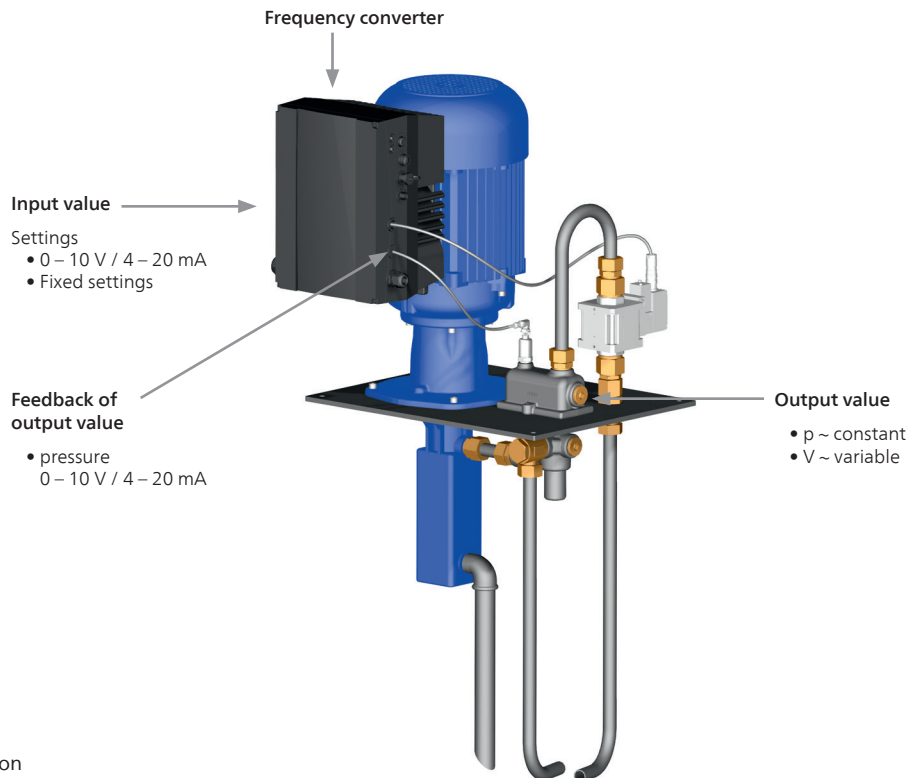

Fig. 1: Scheme of regulation

Control / Regulation

Variable Speed Control of High Pressure Pumps

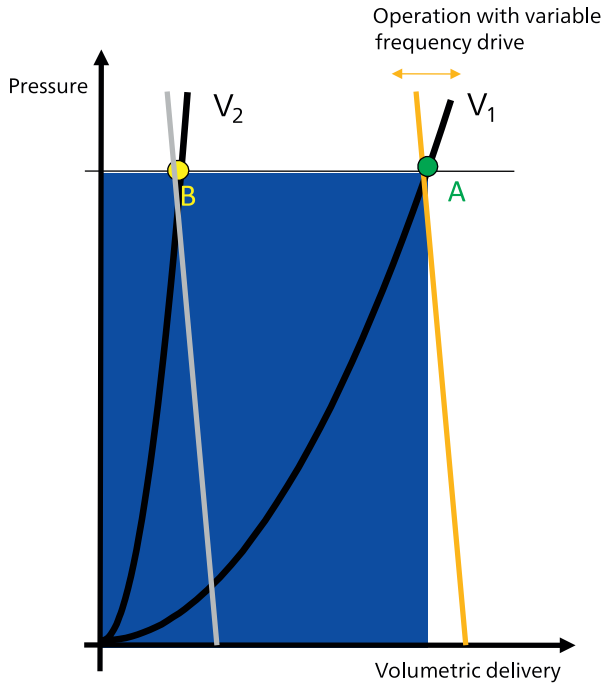

Fig. 2: Potential energy savings of a screw pump with variable frequency drive and two consumers.

Working point	Variable frequency drive	Pressure relief valve	Note
A	no	closed	Design point
B	no	open	Energy loss and flow through the pressure relief valve
B	yes	closed	Energy savings up to 80 % (e.g. pressure regulation)

Pump curve array of a screw pump that is controlled with a VFD

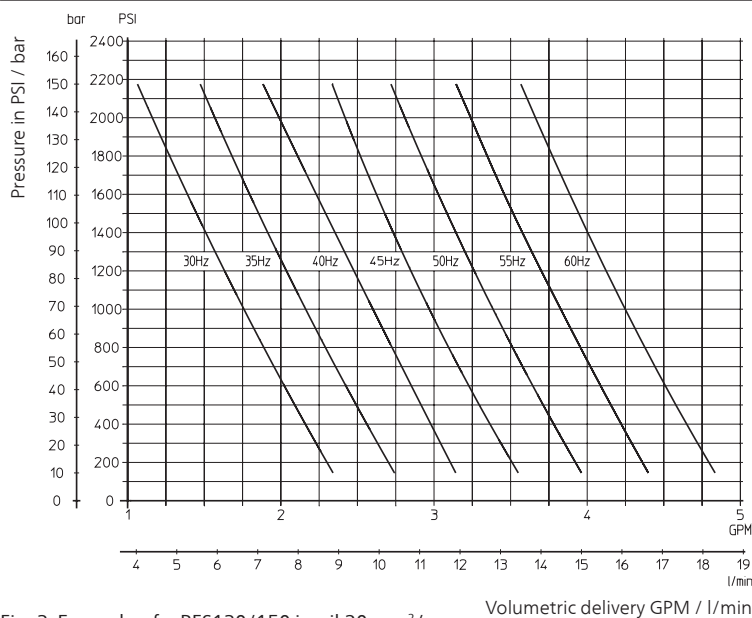
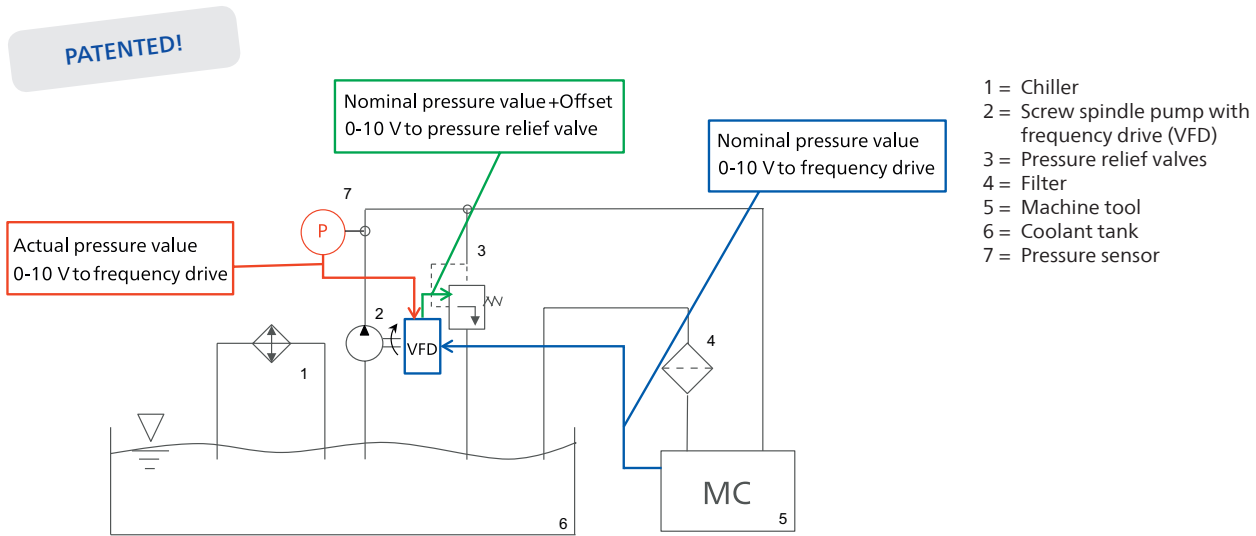

Fig. 3: Example of a BFS130/150 in oil 20 mm²/s

Control / Regulation

Brinkmann Pumps Offset Regulation for High Pressure Pumps

The target pressure is calculated by the VFD based on the working point and is not supplied by the machine tool. The intelligent control of the valves allows for minimizing potential pressure spikes.



Minimizing pressure peaks during tool change

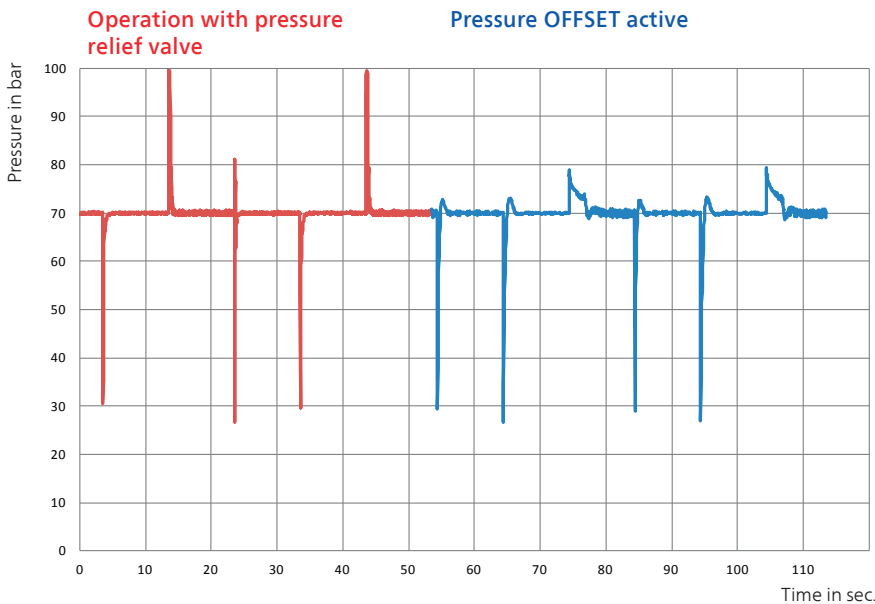

Control / Regulation

TECHNICAL DATA				
Frequency converter FKO (2.0 – 29.5 HP / 1.5 – 22 kW)				
Function	Specification			
Rated voltage	3 AC 380 V -10 % ... 480 V +10 %			
Rated frequency	50/60 Hz ± 6 %			
Output ranges	... 2.0 HP	3.0 – 5.4 HP	7.4 – 10 HP	15 – 29.5 HP
Housing size	A	B	C	D
Protective system	IP 65			IP 55
EMV approvals acc. to EN61800-3US	C2			
Temperature range	14 °F ... 122 °F			
Overload capability	1.5 times rated output current			
Protective functions	undervoltage, overvoltage, I ² t-restriction, short circuit, motor temperature, converter temperature, anti-tilt protection			
Output frequency range	according to layout at factory			
Digital inputs	4			
Fixed frequencies	7			
Digital outputs	2			
Analog inputs	2 analog inputs (0/2 – 10 V, 0/4 – 20 mA)			
Analog outputs	0 – 10 V (-Imax = 10 mA) or 0 – 20 mA (burden R = 500 Ω)			
Process control	PID			
Relay outputs	2 x NO contacts 250 V AC 2 A			
USB interface	USB on plug M12 (RS485/RS232)			
Manual control unit (optional)	MMI with cable			
BUS modules (optional)	PROFIBUS DP, CANopen, EtherCAT, PROFINET			
UL approval	yes			

Dimensions with Brinkmann motor

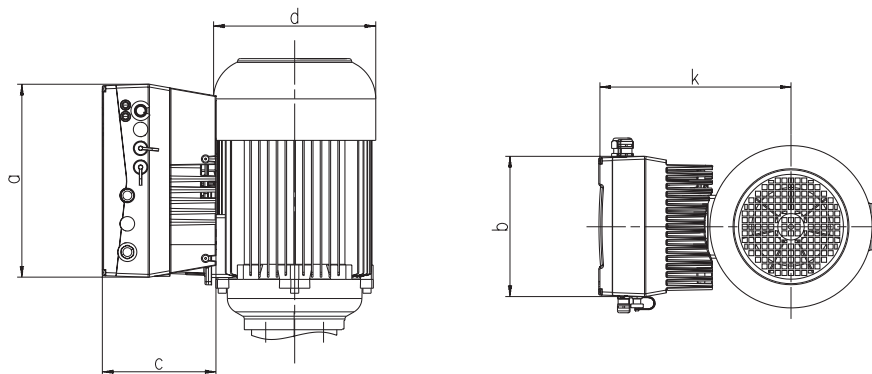

Motor power		housing size	a inch	b inch	c inch	d inch	k inch
kW	HP						
1.1	1.5	A	8.78	6.02	4.72	5.43	7.83
1.3 – 1.7	1.7 – 2.3	A	8.78	6.02	4.72	6.93	8.23
1.9 – 2.6	2.5 – 3.5	B	10.63	7.44	5,51	6.93	8.78
3.0 – 4.0	4.0 – 5.4	B	10.63	7.44	5,51	8.58	9.57
5.0 – 5.5	6.7 – 7.4	C	12.09	8.78	7.13	8.58	11.30
6.0 – 9.0	8.0 – 12.1	C	12.09	8.78	7.13	10.16	12.05
11.0 – 13.0	14.7 – 17.4	D	16.30	11.57	9.17	12.36	15.91