

CUTTER PUMPS

Cutter Pumps

The cutter pumps of the **series SFC** are capable of cutting aluminium chips and similar materials and pumping of these materials along with the coolant fluid. An agitator located at the pump suction helps to break up and separate any large bundles of chips or birds nests which reach the pump suction. The specially made cutting unit (> 60HRC) is cutting chips and the above located semi-open impeller allows with its large clearances to pump the particles along with the coolant fluid from the machine back to the filter. The SFC pumps are capable of handling chip to coolant ratios of up to 1.5% by weight. The SFC pumps are equipped with the user-friendly 45 degree **flange** connection which allows for either vertical or horizontal pipe connection and the connection of a pressure gauge with G 1/4. For more information see lifting pumps features SFC/SBC within the technical information section.



Applications

Types of fluid
 coolants
 cooling/cutting oils on request
 Max. chip to coolant ratio by weight:
 1.5 %
 Chip material:
 Aluminium
 Kinematic viscosity
 ...45 mm²/s (45 cSt)
 Pumping temperature
 0...80° C

Construction

Pump body	cast iron
Cover	cast iron
Impeller radial	cast steel
Cutting unit	Hardened (>60 HRC)
Agitator	Highly ductile steel
Shaft	steel

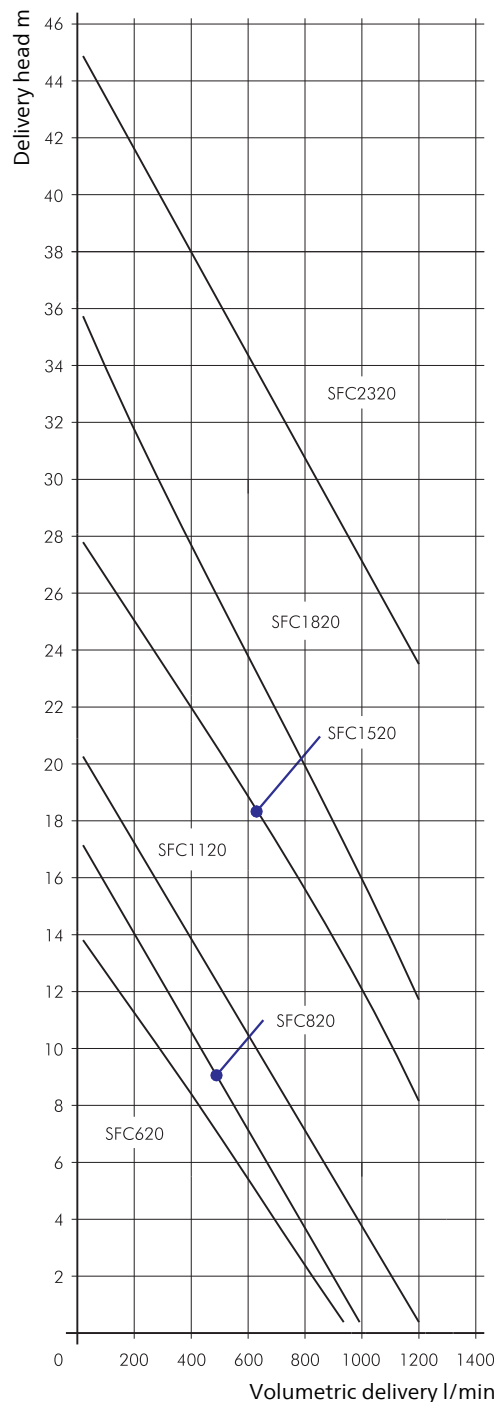

Cutter Pumps

SXC2824

Axial/semi-open impellers

SXC2824

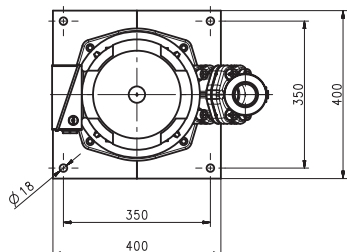
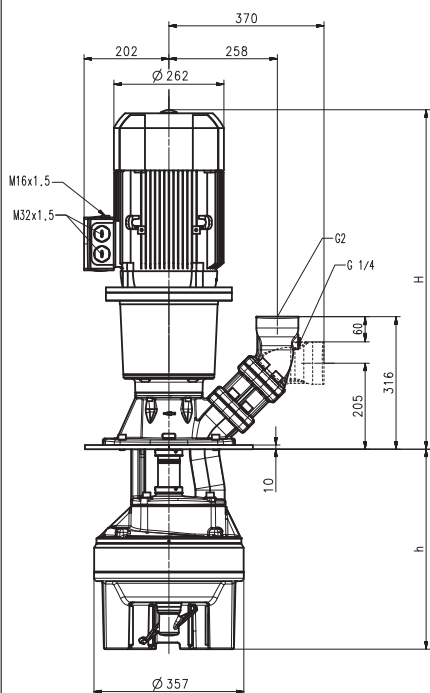

Type	Vol. del. at manom. del. head l/min /m	Height H mm	Depth of immersion h mm	Weight kg	Power (4-pole) kW	Voltage 3~ V	Frequency Hz	Current A	Speed 1/min
SXC2824/480	750/13	809	476	194	7.5	400	50	14.3	1465
	610		606	196					
	730		726	199	8.6	460	60	14.2	1765



Cutter Pumps

The cutter pumps of the **series SXC** are designed to handle low alloyed steels, machining steel and cast iron / aluminum combinations. Chips can also be in the shape of birds nests or chip bundles. The chips must be supplied to the suction inlet of the pump. The chips are being picked up by the agitator then broken up, if necessary, and then cut and delivered by the pump.

The SXC pumps are equipped with the user-friendly 45 degree **flange** connection which allows for either vertical or horizontal pipe connection and the connection of a pressure gauge with G 1/4.

For more information see lifting pumps features SXC/SPC within the technical information section.

Applications

Types of fluid
 coolants
 cooling/cutting oils on request
 Max. chip to coolant ratio by weight:
 0.5 %
 Chip material:
 Low alloyed steel, machining steel,
 cast iron/aluminum combinations
 Kinematic viscosity
 ...45 mm²/s (45 cSt)
 Pumping temperature
 0...80° C

Construction

Pump body	cast iron
Cover	cast iron
Impeller radial	cast steel
Cutting unit	coated (> 60 HRC)
Shaft	steel

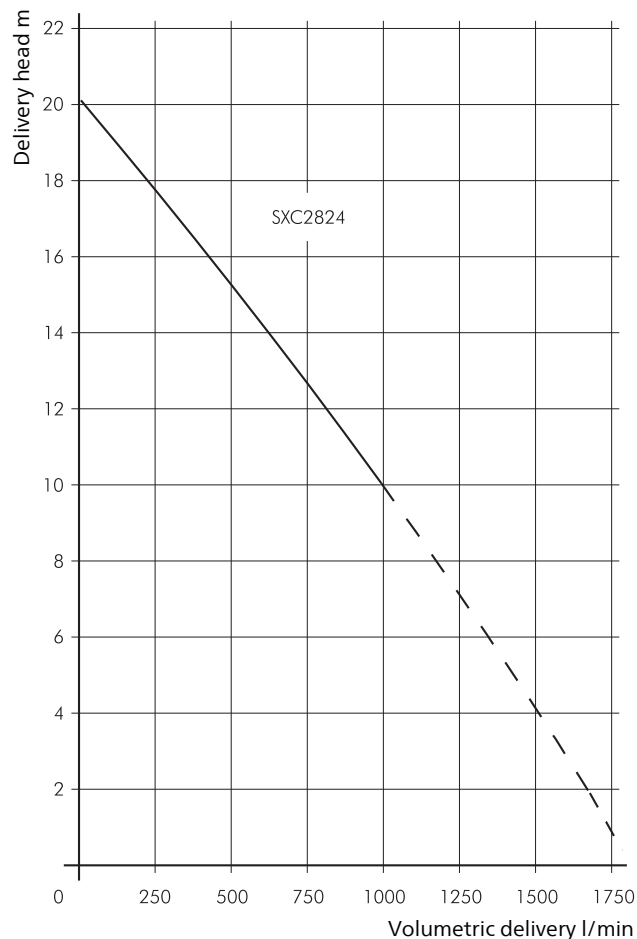

Cutter Pumps

SPC820

Axial/semi-open impellers

SPC820

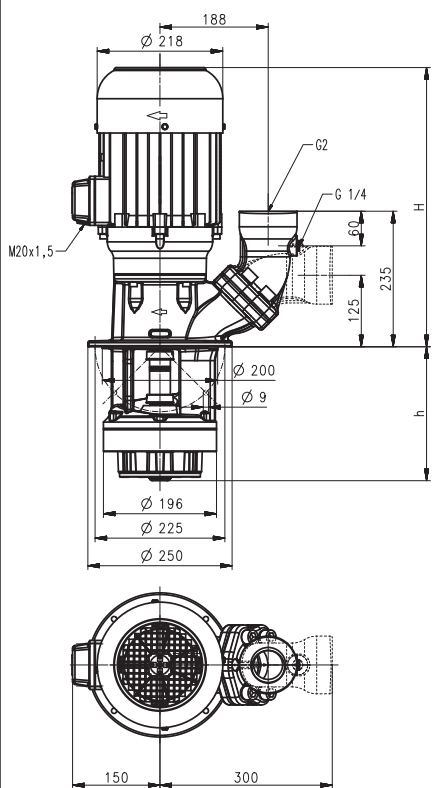

Type	Vol. del. at manom. del. head l/min /m	Height H mm	Depth of immersion h mm	Weight kg	Power kW	Voltage 3~ V	Fre- quen- cy Hz	Current A	Speed 1/min
SPC820/230	400/10.5	503	232	71	3.3	220-240	50	11.6	2930
330			332	73					
460			462	75					
					3.8	460	60	6.4	3520



Cutter Pumps

The cutter pumps of the **series SPC** are designed to handle and reliably cut long, stringy plastic chips. Because of the higher number of cutting blades which results in an increased cutting frequency all chips are being consistently cut in small pieces.

The SPC pumps are equipped with the user-friendly 45 degree **flange** connection which allows for either vertical or horizontal pipe connection and the connection of a pressure gauge with G 1/4.

For more information see lifting pumps features SXC/SPC within the technical information section.

Applications

Types of fluid
 coolants
 cooling/cutting oils
 Max. chip to coolant ratio by weight:
 0.3 %
 Chip material:
 Plastic
 Kinematic viscosity
 ...30 mm²/s (30 cSt)
 Pumping temperature
 0...60° C

Construction

Pump body	cast iron
Cover	cast iron
Impeller radial	cast steel
Cutting unit	Hardened (>60 HRC)
Shaft	steel

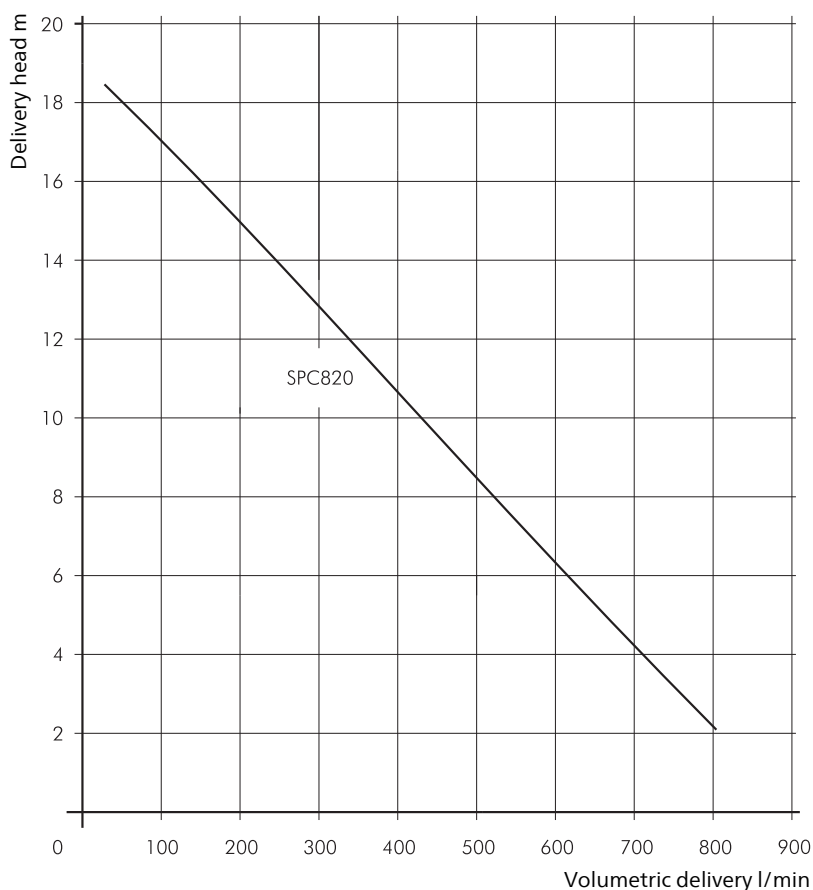

Horizontal End-Suction Pumps

SBC820...1820

Axial/semi-open impellers

SBC820...1120

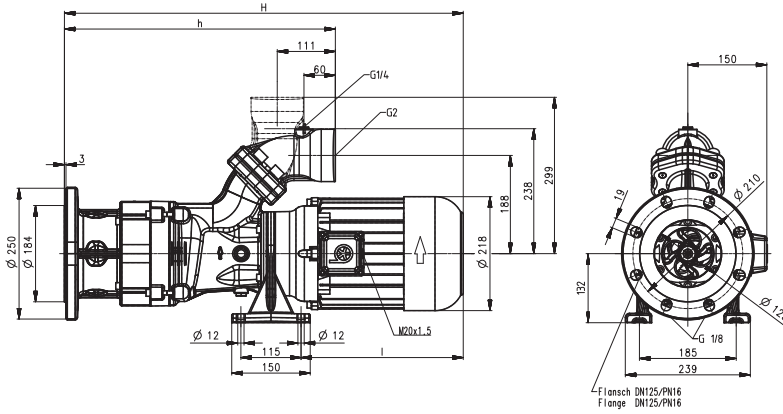

SBC1520...1820

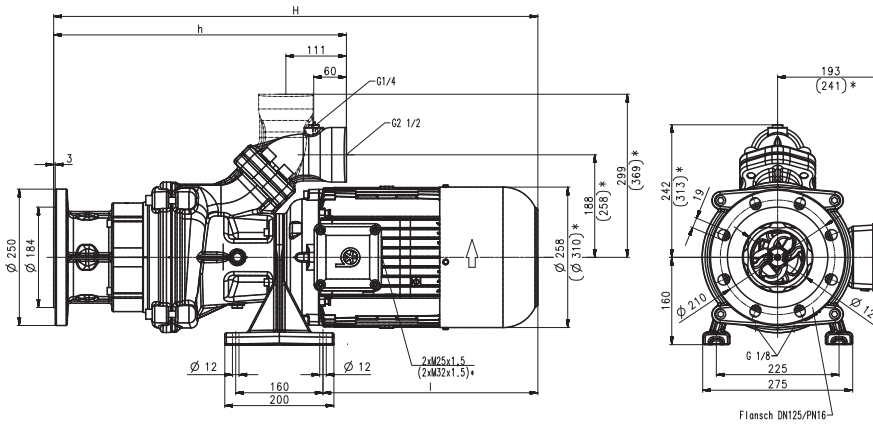

*) Dimensions for SBC1820



Type	Vol. del. at manom. del. head l/min / m	Dimensions		Length l mm	Weight kg	Power kW	Voltage 3 ~ V	Fre- quen- cy Hz	Current A	Speed 1/min
		H mm	h mm							
SBC820	400/10	780	518	328	85	4.0	220-240	50	14.50	2920
							380-415	50	8.35	2920
						4.55	460	60	7.9	3520
SBC1120	600/10	810	518	358	89	5.5	220-240	50	18.9	2915
							380-415	50	10.9	2915
						6.3	460	60	10.4	3510
SBC1520	800/16	906	537	414	132	7.5	380-415	50	14.3	2950
						8.6	460	60	13.7	3550
SBC1820	900/17.5	915	608	422	163	11.0	380-415	50	20.1	2960
						12.6	460	60	19.5	3560

Horizontal End-Suction Pumps

are centrifugal inline pumps with a compact design where the impeller is mounted onto the extended motor shaft. These pumps are not self-priming and must be gravity fed. All pumps are equipped with double mechanical seal. This pump series is designed for horizontal installations next to a tank and are capable of cutting aluminium chips and similar materials and pumping of these materials along with the coolant fluid. An agitator located at the pump suction helps to break up and separate any large bundles of chips or birds nests which reach the pump suction.

The specially made cutting unit (> 60 HRC) is cutting chips and the above located semi-open impeller allows with its large clearances to pump the particles along with the coolant fluid from the machine back to the filter. The SBC pumps are capable of handling chip to coolant ratios of up to 1.5% by weight.

The SBC pumps are equipped with the user-friendly 45 degree **flange** connection which allows for either vertical or horizontal pipe connection and the connection of a pressure gauge with G 1/4.

For more information see lifting pumps features SFC/SBC within the technical information section.



Applications

Types of fluid
coolants
cooling/cutting oils on request
Max. chip to coolant ratio by weight:
1.5 %
Chip material:
Aluminium
Chip geometry:
Chip bundles to max. Ø 100 mm
Kinematic viscosity
...45 mm²/s (45 cSt)
Pumping temperature
0...80° C

Construction

Pump body	cast iron
Cover	cast iron
Impeller axial	cast steel
Impeller radial	cast steel
Cutting unit	Hardened (>60 HRC)
Agitator	Highly ductile steel
Shaft	steel
Mechanical seal	SiC
Noise level	
SBC820...SBC1120	71 dBA
SBC1520...SBC1820	74 dBA

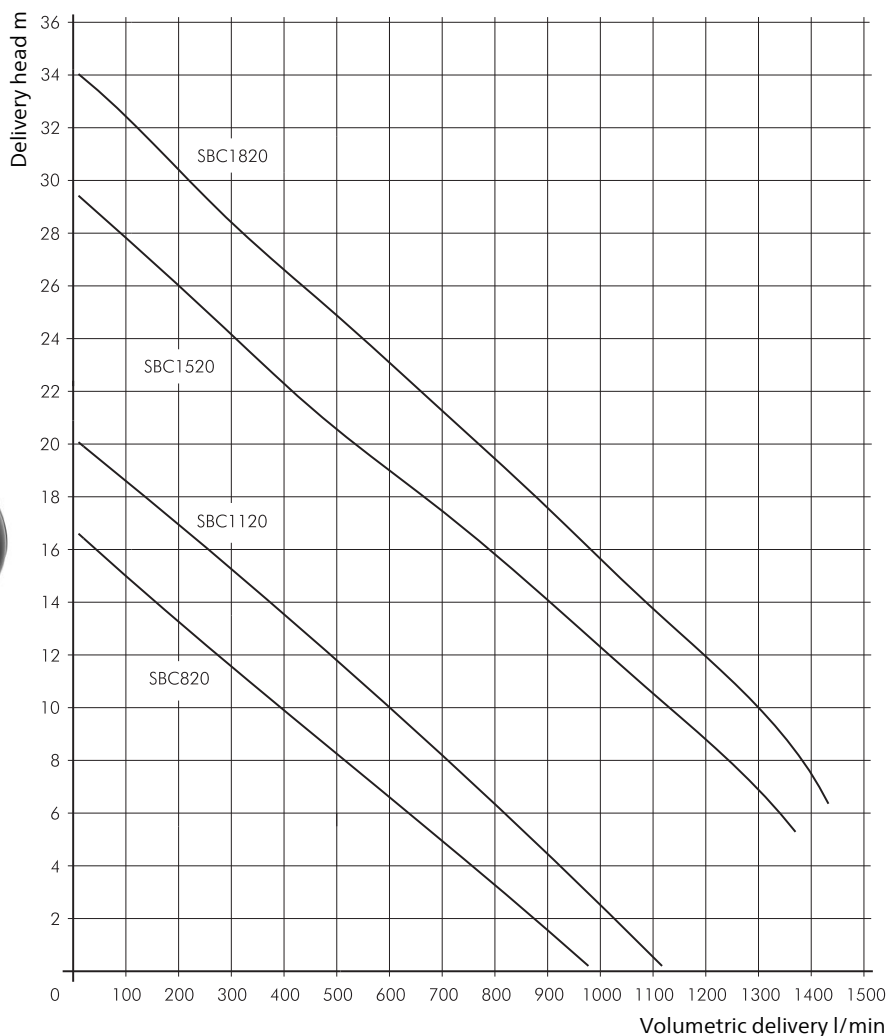



Cutter Pumps SFC

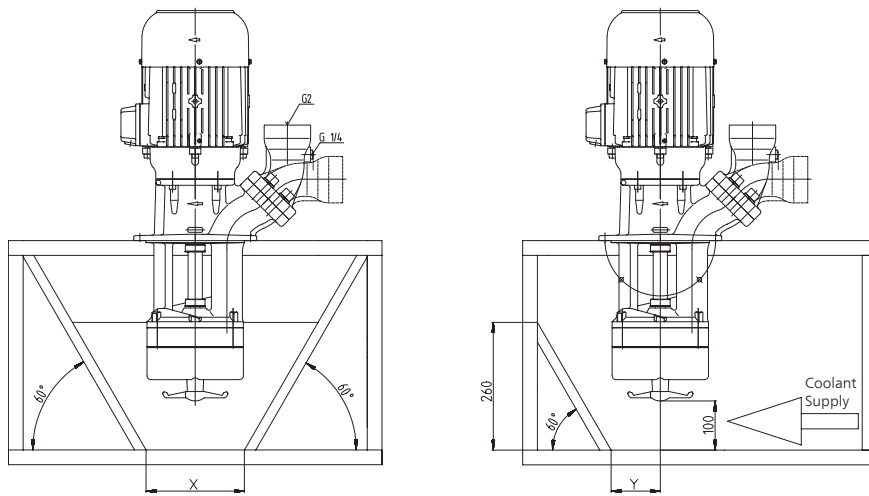

Type	X mm	Y mm
SFC620 SFC820 SFC1120	200	100
SFC1520 SFC1820 SFC2320 SFC3000	275	140

The SFC series cutter pumps are capable of cutting aluminum chips and similar materials and pumping of these materials along with the coolant fluid. An agitator located at the pump suction helps to break up and separate any large bundles of chips or birds nests which reach the pump suction.

The hardened cutting unit (>60HRC) is cutting chips and other materials and the above located semi-open impeller allows with its large clearances to pump the particles along with the coolant fluid from the machine back to the filter. The SFC pumps are capable of handling chip to coolant ratios of up to 1.5 % by weight. The cutter pump is equipped with a maintenance free shock absorbing bushing which has outstanding dry running capabilities. Instead of cycling the pumps,

Pumps of the SFC series have the following unique characteristics:

- Oversized motor to transfer additional cutting forces via the driving shaft if necessary
- Axial impeller which has been optimized for the cutting process
- Dry running capability
- Adjustable gap between both cutting blades for preventive maintenance (due to stiff motor bearing and shaft design)
- Maintenance free and shock absorbing bearing bushing

the SFC pumps should be run continuously in order to prevent chips from entering the back plane of the impeller. The minimum distance of 100 mm between the bottom of the tank and the agitator must always be maintained in order to prevent unwanted foreign objects, such as broken tool parts, from entering pump and damaging the cutting mechanism. The tank bottom must be checked and any foreign objects must be removed regularly.

The walls of the tank around the pump should be sloped at a 60 degree angle to avoid chips from gathering inside the tank. The coolant supply should be aimed directly at the pump to ensure that also large bundles of chips reach the pump suction (please refer to the above tank design as a guide line for your tank layout).

Cutter Pumps SBC

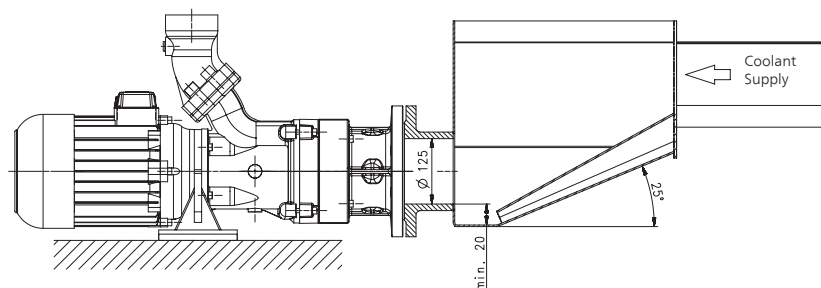

SBC pumps are comparable to SFC pumps from a technical standpoint. When directly mounted to the tank or to the machine tool preventive actions must be taken in order to avoid unwanted foreign objects, such as broken tooling pieces, from reaching the pump suction.

All information stated above is only intended as a general guide line for your system layout. Prior to placing your order please consult with our highly skilled sales force regarding your specific application in order to ensure proper pump selection.



Cutter Pumps SXC | SXC-R | SXC-H

SXC

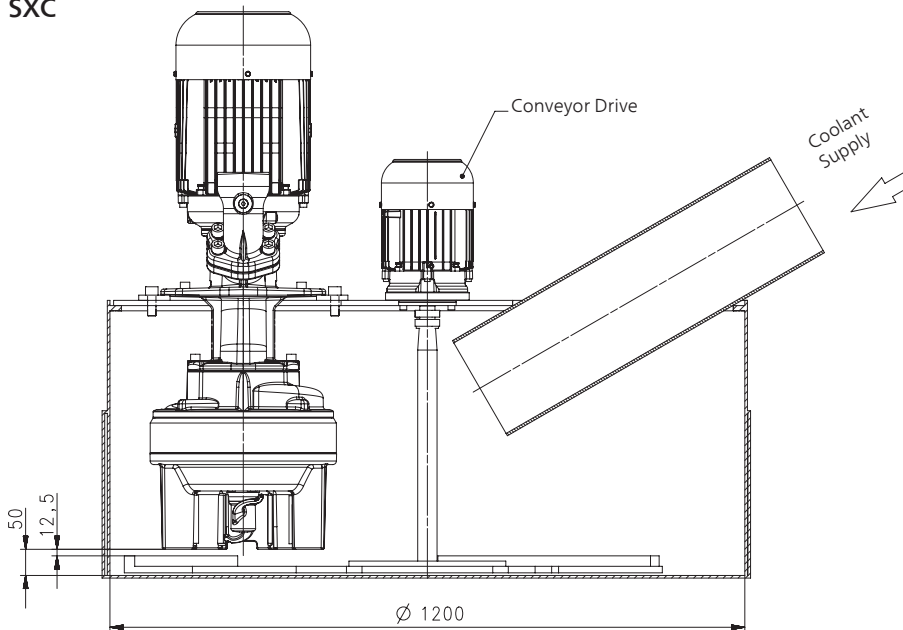

SXC-R

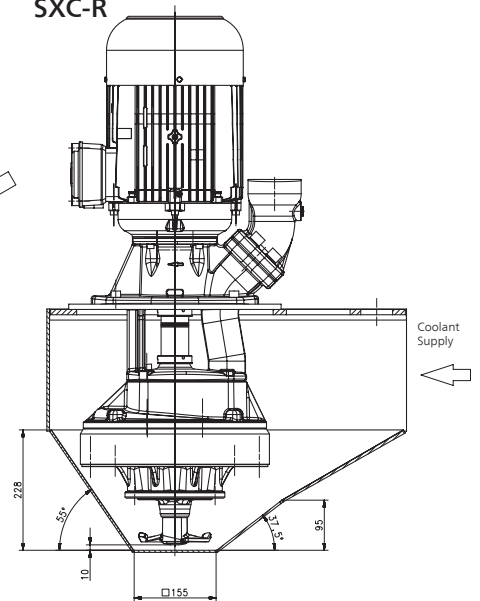

The cutter pumps of the series SXC are designed to handle low alloyed steels, machining steel (SXC-H) and cast iron / aluminum combinations (SXC). Chips can also be in the shape of birds nests or chip bundles.

The chips must be supplied to the suction

inlet of the pump, which are then picked up by the agitator broken up if necessary, and then cut and delivered by the pump.

In the case of brittle chips, such as cast iron rings, the SXC-R pump, which has an agitator that is capable of picking up the chips of the tank bottom, is to be applied.

Proper tank design which ensures that all chips get to the pump suction is critical for all pump types.

Due to the complexity of this application we recommend to consult with our technical application specialists in order to ensure the proper pump selection.

Cutter Pumps SPC

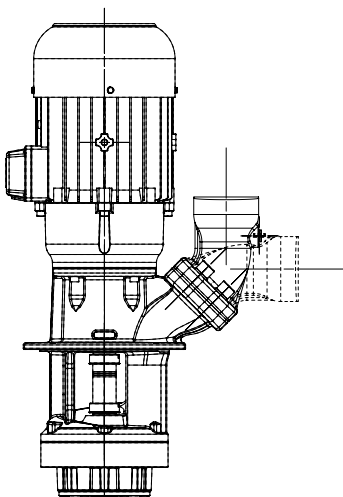

The cutter pumps of the series SPC are designed to handle and reliably cut long, stringy plastic chips.

Because of the higher number of cutting blades which results in an increased cutting frequency all chips are being consistently cut in small pieces.

Mixer IMX

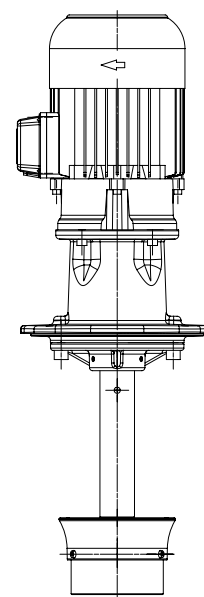

The IMX mixer is used to maintain a constant circulation of the fluid within the tank in order to prevent settling out of any sedimentation. Another popular application field for the mixer is to skim off and destroy any grinding wool and swarf mats that are accumulating on the coolant surface.

All information stated above is only intended as a general guide line for your system layout. Prior to placing your order please consult with our highly skilled sales force regarding your specific application in order to ensure proper pump selection.

The Brinkmann Pumps network – This is the way to find us.



BRINKMANN PUMPS has a global presence and direct representation throughout Europe, Asia and North America. This ensures quick response times, competent consulting personnel and the highest level of service, which Brinkmann Pumps is known for, anytime and anywhere. Visit our website – where you will find all the contact details for our representative offices. Visit us and convince yourself of our capabilities.

Welcome to BRINKMANN PUMPS.



BRINKMANN PUMPS

K.H. Brinkmann GmbH & Co. KG
Friedrichstraße 2
58791 Werdohl
Germany

Brinkmann Pumps Inc.
47060 Cartier Drive
Wixom, MI 48393
United States

Brinkmann Pumps Japan Co. Ltd.
2-19-12, Engyo Fujisawa
Kanagawa, 252-0805
Japan

T +49 2392 5006-0
F +49 2392 5006-180
sales@brinkmannpumps.de
www.brinkmannpumps.de

T +1 248 926 9400
F +1 248 926 9405
sales@brinkmannpumps.com
www.brinkmannpumps.com

T +81 466 778320
F +81 466 778321
sales@brinkmannpumps.jp
www.brinkmannpumps.jp