

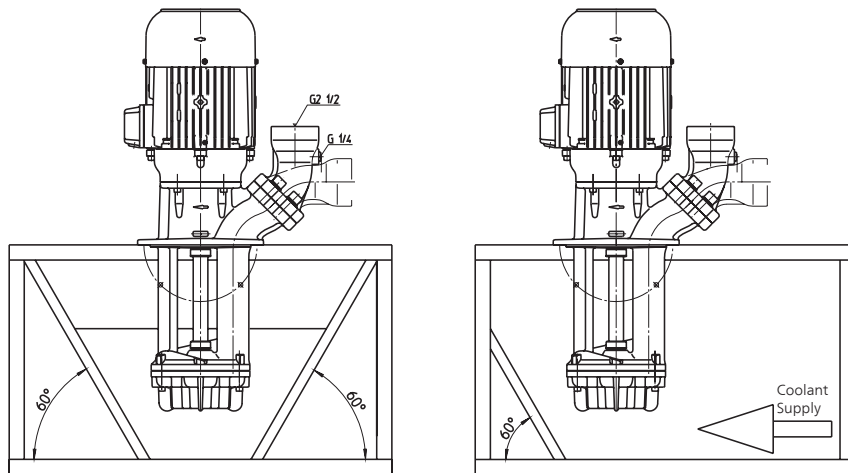

Lifting Pumps SFL



The SFL pump series represents an innovative lift pump concept which has found many pumpback applications world wide. The SFL pumps series can be customized through various options and upgrades.

Properly planned system and tank design allow for the possibility to use the **SFL** and **SFC Cutter pumps** interchangeably within the same tank in order to ensure maximum flexibility with respect to being able to react to changing machining materials or different chip geometries.

	Impeller material	Inlet cover material	Slurping mode	Chip handling capabilities	Max. chip to coolant ratio by weight
SFL...Standard TFL250	cast steel	special cast iron	yes	coloured metal, aluminium, cast iron	1 %
SFL...CM1	CrMo	special cast iron	yes	steel, medium alloyed steel	1 %
SFL...CM3	CrMo	CrMo	yes	forged materials high alloyed steels hardened steels	1 %
SFL...CM4	CrMo	CrMo	yes	forged materials high alloyed steels hardened steels	1 %

Type	Chip diameter mm	Chip length mm
TFL250	7	15
SFL550	8	15
SFL650	8	15
SFL850	10	20
SFL1150	15	30
SFL1350	15	30
SFL1550	15	30
SFL1850	15	30
SFL2350	25	50

We gladly support you regarding any questions on pump regulation and control. A „saw-tooth operation“ with two different pump speeds might just be the perfect solution for you.

Lifting Pumps SBF

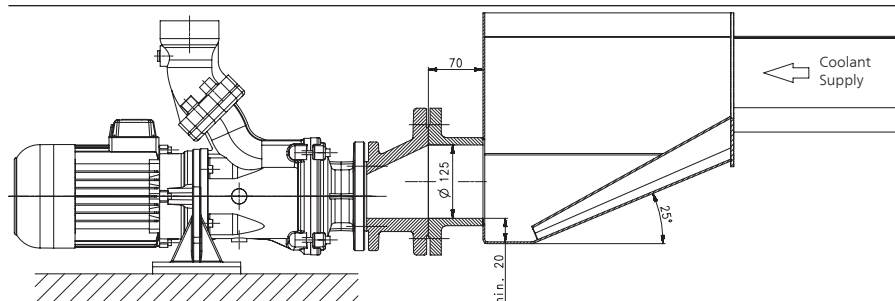

SBF pumps are comparable to SFL pumps from a technical standpoint. These pumps can be mounted directly to the machine and are available upon request with upgraded materials of construction which allow for unlimited dry-running (double mechanical seal).

Properly planned system and tank design allow for the possibility to use **SBF** and **SBC cutter pumps** interchangeably within the same tank by only adding an adapter flange.

Option:

SFL and **SBF pumps** are also available with an additional agitator at the pump suction. The agitator can either be supplied directly with the pump assembly or is available as a separate component for installation in the field at a later date.

All information stated above is only intended as a general guide line for your system layout. Prior to placing your order please consult with our highly skilled sales force regarding your specific application in order to ensure proper pump selection.



Cutter Pumps SFC

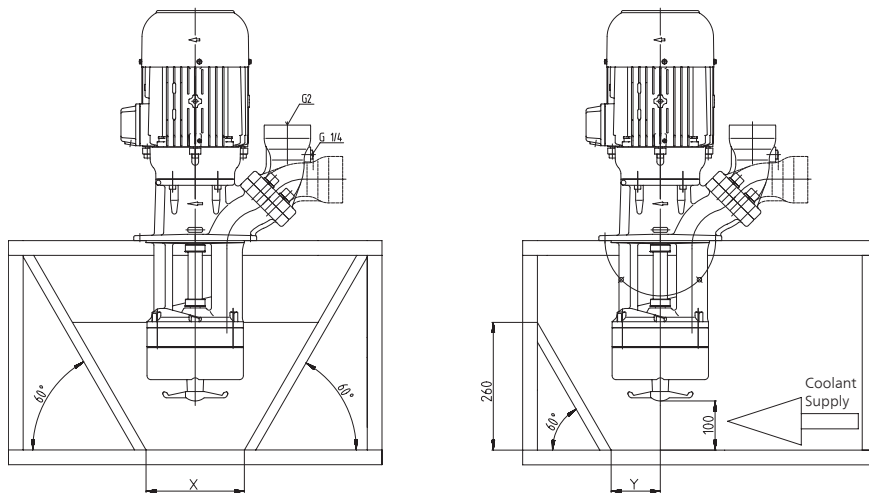

Pumps of the SFC series have the following unique characteristics:

- Oversized motor to transfer additional cutting forces via the driving shaft if necessary
- Axial impeller which has been optimized for the cutting process
- Dry running capability
- Adjustable gap between both cutting blades for preventive maintenance (due to stiff motor bearing and shaft design)
- Maintenance free and shock absorbing bearing bushing

Type	X mm	Y mm
SFC420	140	70
SFC620 SFC820 SFC1120	200	100
SFC1520 SFC1820 SFC2320	275	140

The SFC series cutter pumps are capable of cutting aluminum chips and similar materials and pumping of these materials along with the coolant fluid. An agitator located at the pump suction helps to break up and separate any large bundles of chips or birds nests which reach the pump suction.

The hardened cutting unit (>60HRC) is cutting chips and other materials and the above located semi-open impeller allows with its large clearances to pump the particles along with the coolant fluid from the machine back to the filter. The SFC pumps are capable of handling chip to coolant ratios of up to 1.5 % by weight. The cutter pump is equipped with a maintenance free shock absorbing bushing which has outstanding dry running capabilities. Instead of cycling the pumps,

the SFC pumps should be run continuously in order to prevent chips from entering the back plane of the impeller. The minimum distance of 100 mm between the bottom of the tank and the agitator must always be maintained in order to prevent unwanted foreign objects, such as broken tool parts, from entering pump and damaging the cutting mechanism. The tank bottom must be checked and any foreign objects must be removed regularly.

The walls of the tank around the pump should be sloped at a 60 degree angle to avoid chips from gathering inside the tank. The coolant supply should be aimed directly at the pump to ensure that also large bundles of chips reach the pump suction (please refer to the above tank design as a guide line for your tank layout).

Cutter Pumps SBC

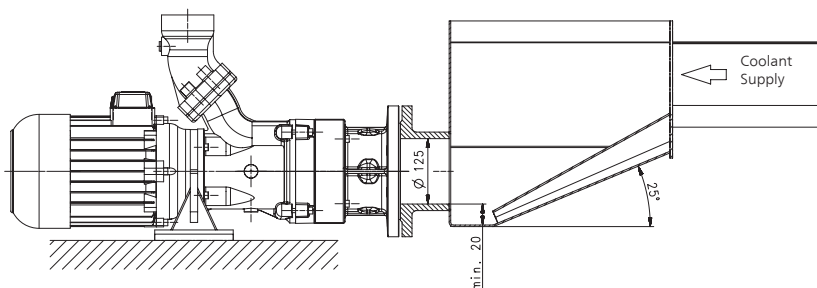

SBC pumps are comparable to SFC pumps from a technical standpoint. When directly mounted to the tank or to the machine tool preventive actions must be taken in order to avoid unwanted foreign objects, such as broken tooling pieces, from reaching the pump suction.

All information stated above is only intended as a general guide line for your system layout. Prior to placing your order please consult with our highly skilled sales force regarding your specific application in order to ensure proper pump selection.



Cutter Pumps SXC | SXC-R | SXC-H

SXC

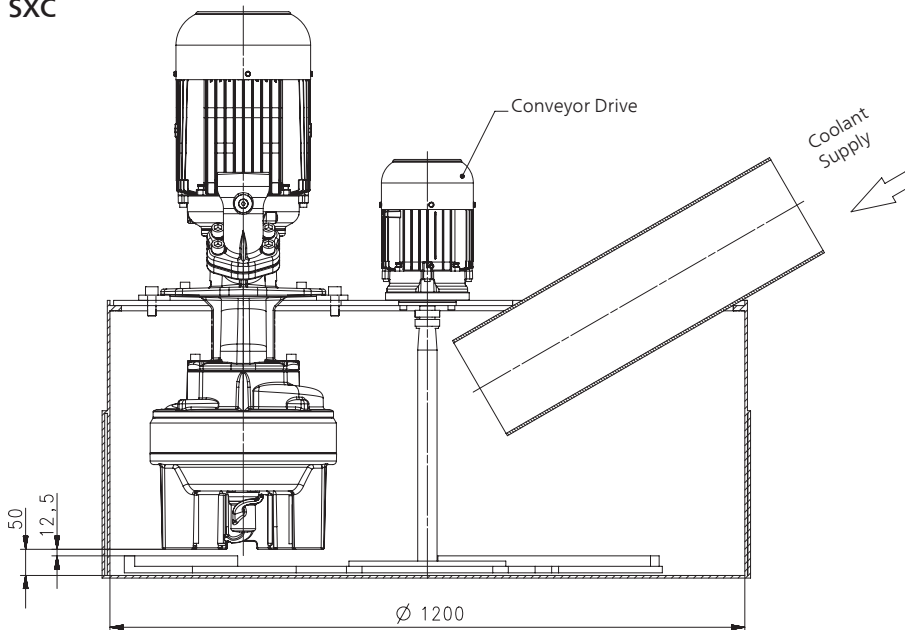

The cutter pumps of the series SXC are designed to handle low alloyed steels, machining steel (SXC-H) and cast iron / aluminum combinations (SXC). Chips can also be in the shape of birds nests or chip bundles.

The chips must be supplied to the suction

inlet of the pump, which are then picked up by the agitator broken up if necessary, and then cut and delivered by the pump.

In the case of brittle chips, such as cast iron rings, the SXC-R pump, which has an agitator that is capable of picking up the chips of the tank bottom, is to be applied.

SXC-R

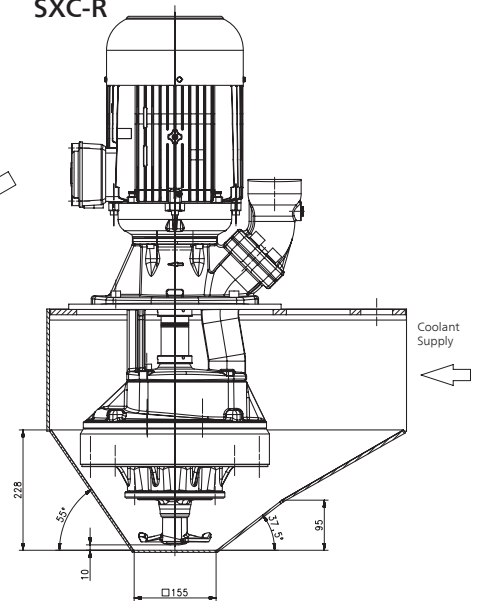

Proper tank design which ensures that all chips get to the pump suction is critical for all pump types.

Due to the complexity of this application we recommend to consult with our technical application specialists in order to ensure the proper pump selection.

Cutter Pumps SPC

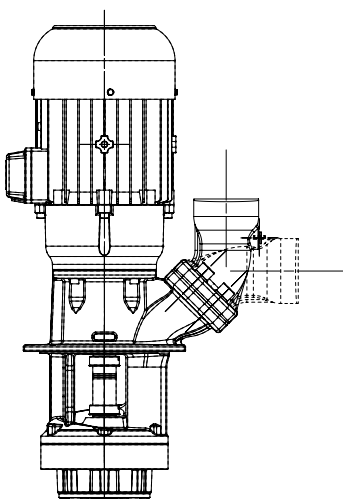

The cutter pumps of the series SPC are designed to handle and reliably cut long, stringy plastic chips.

Because of the higher number of cutting blades which results in an increased cutting frequency all chips are being consistently cut in small pieces.

Mixer IMX

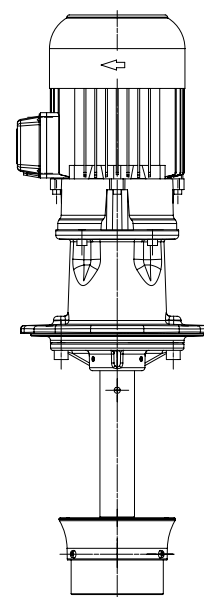

The IMX mixer is used to maintain a constant circulation of the fluid within the tank in order to prevent settling out of any sedimentation. Another popular application field for the mixer is to skim off and destroy any grinding wool and swarf mats that are accumulating on the coolant surface.

All information stated above is only intended as a general guide line for your system layout. Prior to placing your order please consult with our highly skilled sales force regarding your specific application in order to ensure proper pump selection.

Lifting pump versions SFT



Vortex Pumps SFT

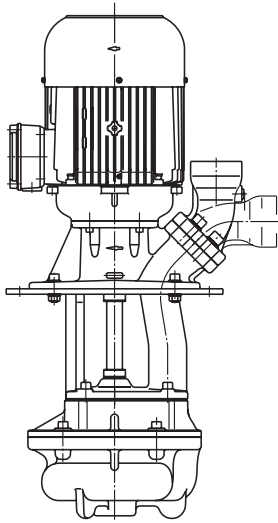

Vortex pumps are traditional lift pumps with a recessed impeller that allows for a sphere passage of up to 50 mm. In order to ensure stable operating conditions the impeller must be fully flooded, and the pump must lift the fluid at least 3 – 8 m above the pump discharge.

	Impeller material	Inlet cover material	Shaft bushing	Max. chip to coolant ratio by weight	sphere size passage mm	Chip handling capabilities
SFT450 SFT710 SFT1100	Cast steel	Special cast iron	SIC/SIC	1.5 %	50	colored metal aluminium cast iron steel alloyed steel hardened steel forged steel
SFT1300 SFT1350 SFT1400 SFT2254 SFT3054 SFT3554	Cast steel	Special cast iron	Cartridge	1.5 %	45	
SFT1554-C	Cast steel	Special cast iron	Cartridge	1.5 %	40	

All information stated above is only intended as a general guide line for your system layout. Prior to placing your order please consult with our highly skilled sales force regarding your specific application in order to ensure proper pump selection.